

FW VERSION - CUSCINETTI A SFERE / BALL BEARINGS - 1450 RPM

ONLY FOR MODELS 3525 S-E 4022 S-E

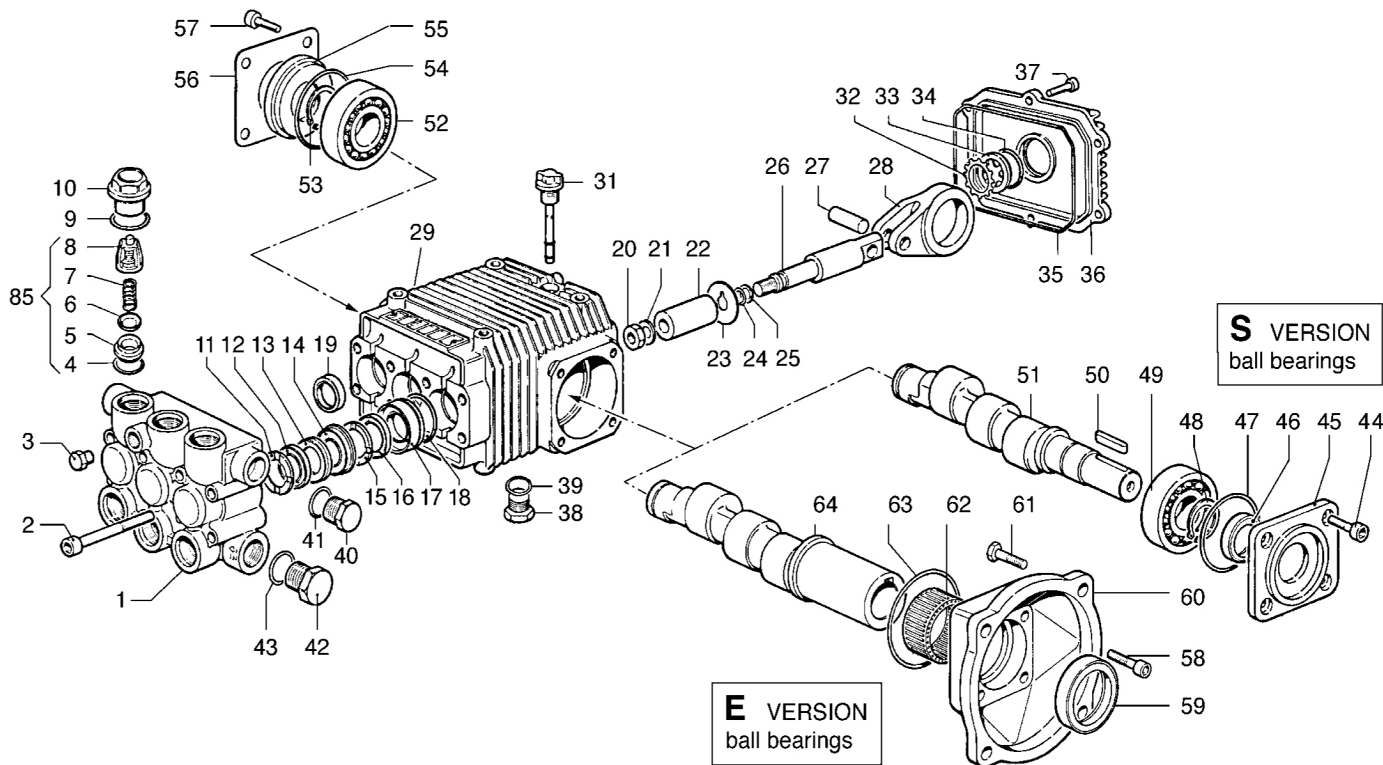

ITEM	PART No.	KIT	DESCRIPTION	Qty.	MODELS
1	3218.0110.00		MANIFOLD Ø 18 mm	1	
2	3609.0039.00		SCREW M8X70	8	
3	3202.0112.00		CAP G1/4	1	
4	1210.0046.00	A-D	O-RING 2,62X 17,13 mm	6	
5	3009.0087.00	A	VALVE SEAT	6	
6	3604.0017.00	A	VALVE PLATE	6	
7	1802.0177.00	A	SPRING	6	
8	1205.0025.00	A	VALVE CAGE	6	
9	1210.0048.00	A-D	O-RING 2,62X 20,24 mm	6	
10	3202.0155.00		CAP	6	
11	0009.0199.00	B	HEAD RING Ø18 mm	3	
12	1241.0026.00	B	PACKING Ø18 mm	3	
13	0009.0100.00	B	PACKING Ø18 mm	3	
14	0009.0200.00		INTERMED. RING Ø18 mm	3	
15	0009.0199.00	B	HEAD RING Ø18 mm	3	
16	1241.0026.00	B	PACKING Ø18 mm	3	
17	0009.0102.00		PACKING RETAINER Ø18mm	3	
18	1210.0156.00	B-D	O-RING 1,78X31,47 mm	3	
19	0019.0066.00	D	OIL SEAL 20X30X5 mm	3	
20	0600.0054.00	C	NUT	3	
21	2811.0082.00	C	WASHER 8,2X17X1,5 mm	3	
22	0202.0022.00	C	PISTON Ø18	3	
23	2812.0042.00	C	WASHER	3	
24	1210.0039.00	C-D	O-RING 1,78X 7,66 mm	3	
25	0009.0170.00	C-D	ANTI-EXTR. RING	3	
26	2409.0048.00		PISTON GUIDES	3	
27	3011.0016.00		WRIST. PIN Ø10X29 mm	3	
28	0205.0046.00		CON. ROD	3	
29	0403.0129.00		CRANKCASE	1	3525 S - 4022 S
	0403.0130.00		CRANKCASE	1	3525 E - 4022 E
31	3200.0051.00		OIL DIPSTICK	1	
32	3019.0033.00		SNAP RING Ø18 mm	1	
33	3201.0012.00		OIL INDICATOR	1	
34	1210.0333.00	D	O-RING 1,78X23,52 mm	1	
35	1210.0216.00	D	O-RING 2,62X107,62 mm	1	
36	0402.0169.00		CRANKCASE COVER	1	
37	3609.0030.00		SCREW M5X20	6	
38	3200.0007.00		CAP 3/8 GAS	1	
39	1210.0441.00	D	O-RING 2x14 mm	1	
40	3200.0007.00		CAP 3/8 GAS	1	
41	2811.0084.00		WASHER 16,7X22X1,5 mm	1	

ITEM	PART No.	KIT	DESCRIPTION	Qty.	MODELS
42	3202.0015.00		CAP G1/2	1	
43	2811.0086.00		WASHER 21,2X27X1,5 mm	1	
52	0438.0071.00		BALL BEARING 25X62X17 mm	1	
53	3019.0006.00		SNAP RING C72	1	
54	1210.0387.00	D	O-RING 3,53X55,56 mm	1	
55	0402.0176.00		SPACER	1	
56	1004.0015.00		CRANKCASE COVER	1	
57	3609.0068.00		SCREW M6X12	4	
85	1220.0030.00		VALVE ASS. BLY.	6	

S version

ITEM	PART No.	KIT	DESCRIPTION	Qty.	MODELS
44	3609.0058.00		SCREW M8X22	4	
45	0402.0170.00		FLANGE	1	
46	0019.0007.00	D	OIL SEAL 25X52X7 mm	1	
47	1210.0388.00	D	O-RING	1	
48	3019.0006.00		SNAP RING C72	1	
49	0438.0071.00		BALL BEARING 25X62X17 mm	1	
50	1602.0013.00		KEY 8X7X30	1	
51	0001.0324.00		CRANKSHAFT Ø24 mm	1	3525 S
	0001.0325.00		CRANKSHAFT Ø24 mm	1	4022 S

E version

ITEM	PART No.	KIT	DESCRIPTION	Qty.	MODELS
58	3609.0058.00		SCREW M8X22	4	
59	0019.0052.00	D	OIL SEAL 40X52X7 mm	1	
60	3016.0018.00		FLANGE	1	
61	3607.0026.00		SCREW M8X25	4	
62	0437.0027.00		NEEDLE 40X47X20 mm	1	
63	1210.0150.00	D	O-RING 2,62X63,17 mm	1	
64	0001.0326.00		CRANKSHAFT Ø28 mm	1	3525 E
	0001.0328.00		CRANKSHAFT Ø28 mm	1	4022 E